



## SQ FULL RANGE DIGITAL AMPLIFIER

SQ800.4  
SQ1400.5



## OWNERS MANUAL

---

Please read through this manual to familiarize yourself with your new amplifier. Should your Image Dynamics mobile amplifier ever require service, you will need to have the original dated receipt.

## FULL RANGE CLASS D AMPLIFIERS

Thank you for your decision to purchase a Image Dynamics mobile amplifier! Our new amplifiers are the result of extensive engineering, testing, and bullet proof construction. Their versatility enables compatibility with optional signal and audio processors. These high quality MOSFET amplifiers may be configured to allow maximum flexibility in designing different types of speaker systems.

The Image Dynamics SQ Series are high quality MOSFET amplifiers that are capable of running a system full range, or they may be selected only to power subwoofers. It is important that you closely follow the wiring instructions contained in this Owners Manual so that you get the most from your Image Dynamics mobile amplifier.



---

### Δ Caution Δ

High powered audio systems in a vehicle are capable of generating higher than "Live Concert" levels of sound pressure. Continued exposure to excessively high volume sound levels could cause hearing loss or damage. Also, operation of a motor vehicle while listening to audio equipment at high volume levels may impair your ability to hear external sounds such as horns, warning signals, or emergency vehicles—thus creating a potential traffic hazard. In the interest of safety, Image Dynamics USA highly recommends listening at lower volume levels when driving.

---

## TECHNICAL FEATURES

- FRD (Full Range Class-D) technology
- International Rectifier® Chip Set
- Ultra Low Current Draw
- High Damping Control Circuit
- High Efficiency SMD Circuit Technology
- Double Sided Copper Plated 4-Layer PCB
- Digital Sound Optimization Circuitry
- Quiet Switching
- High Current Voltage Ripple Rejection Circuitry
- Virtual Silence Turn On/Off Mute Circuit
- Advanced Protection Circuitry
- Balanced RCA Input Connectors
- 40 Click HPF/LPF Tone Controls
- Fan Cooling (SQ1400.5)

## FRD-FULL RANGE CLASS D TECHNOLOGY

This amplifier represents the very latest in Class D technology. The SQ Series uses the new IR® (International Rectifier) platform which has been under development for the past several years. IR®, a leader in PWM circuit design, has worked in conjunction with Image Dynamics engineers to produce more stable power output, minimal RF interference and improved sound quality.

The benefits of this cooperative effort are many and include improved temperature, frequency, voltage regulation and drive capability to name a few.

The result to the user is a all around improved product that will provide years of listening enjoyment.



IR® is a registered trademark of International Rectifier Corporation.

## INSTALLATION EXPERIENCE

Installation of Image Dynamics mobile amplifiers requires detailed knowledge of electronics wiring and proper speaker impedance. We strongly recommend installation by an authorized Image Dynamics dealer. This Owners Manual only provides general installation and operation instructions. If you have any reservations about your installation skills, please contact your local Image Dynamics dealer for assistance.

**IMPORTANT :** This amplifier is designed for operation in vehicles with 12-volt Negative ground electrical systems only.

## PREPARING FOR INSTALLATION

---

**NOTE:** The tools listed below may be required for basic installation

---

- An electric drill with bits
- Philips head and standard screwdrivers
- Wire strippers
- Crimping tool
- VOM (electronic volt ohm meter)
- Heat shrink tubing and heat gun
- Soldering iron
- Electronic (Rosen not Acid Core) Solder

## INSTALLATION PRECAUTIONS

---

**NOTE:** Proceed only if you are a qualified installer, otherwise, see your Authorized Image Dynamics Dealer to professionally install this amplifier. Always wear protective eyewear when using tools.

---

- Turn off all stereo and other electrical devices before you begin.
- Disconnect the negative (-) lead from your vehicles battery.
- Locate all fuel lines, brake lines, oil lines, and electrical cables when planning the install.
- Make sure there is at least 2-inches (5 cm) around the air vents on the amplifier.
- When connecting ground points, make sure all paint is carefully scrapped away from the auto body and contact is made with bare metal.
- Use a utility knife to trim away fabric from hole locations before drilling or cutting.
- When running power cables through sheet metal, be sure to use grommets to properly insulate the metal edges from the wire insulation.
- If possible, use tubing through grommets.

---

**WARNING:** Check your vehicle's owner's manual before disconnecting the battery. Disconnecting the battery on some vehicles may require an anti-theft code when reconnecting the battery and require the on-board computer to be reset at the dealership. Check with your local dealer if you are uncertain.

---

Fan (SQ1400.5 only)

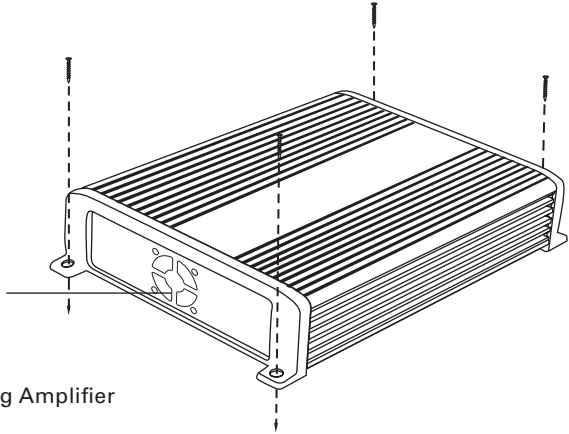

Fig.1 Mounting Amplifier

To keep your Image Dynamics running at top performance, choosing the proper location is of utmost importance. Both Thermal and Overload protection are built in. In the event of overheating, the amplifier may temporarily shut down operation. For this reason the amplifier should be mounted in a location which will allow air to circulate freely.

## MOUNTING LOCATION

Find a clear and well ventilated area to mount your amplifier that is unobstructed by any objects that will cause harm or block ventilation. Despite the fact that this amplifier is compact, it still needs air to cool the heatsink fins. Do not mount under a carpet or an area with dead or stagnant air. Without proper air flow the amplifier may overheat and go into protection where the thermal overload circuitry will shut down the amplifier.

---

**NOTE:** Make sure not to block the cooling fan (SQ-1400.5 only)

---

The amplifier should be protected from exposure to moisture and direct sunlight. The compact size of the amplifier allows greater flexibility in mounting. The best places to mount your amplifier are: The floor of the trunk, under the driver's seat, or on the back of the rear seat. For alternate installation locations, please consult your authorized Image Dynamics Dealer.

If mounting under a seat, make sure there is at least 1-inch (2.5cm) of space above the amplifiers heatsink to permit proper cooling.

You may use the amplifier as a template and mark the four screw locations with a felt tip pen. Set the amplifier aside before drilling. Use caution to make sure there are no objects behind the installation surface that may become damaged during drilling.

---

**NOTE:** Do not use a drill with a driver bit to mount the amplifier. Excessive force could cause the plastic mounting feet to crack.

---

## FUSE REQUIREMENTS

While the panel your Image Dynamics amplifier incorporates one or more fuses, these do nothing to protect the vehicle from a dangerous short circuit. It is absolutely vital that the main power lead to the amplifier(s) in the system be fused within 18-inches (45cm) of the connection to the vehicle battery. The value of this fuse (or circuit breaker) should be no greater than the sum of the fuses found on all of the equipment being connected to that power wire.

SQ1400.5- 100 Amp Fuse

SQ800.4- 60 Amp Fuse

---

NOTE: Due to space limitations, the SQ 1400.5 does NOT use chassis mounted protective fuses. Therefore you must add a fuse and fuse holder (not included) rated at 100A for each SQ 1400.5 installed.

---

### **\*\*\* WARNING \*\*\***

- Do not install in a place where it could injure the driver or passengers if the vehicle stops suddenly.
- Upside down mounting will compromise heat dissipation through the heatsink and could engage the Advanced Protection Circuitry.
- Try to avoid mounting the amplifier on a subwoofer enclosure, as extended exposure to vibration may cause malfunction of the amplifier.
- Don't mount the amplifier so that the wire connections are unprotected or are subject to pinching or damage from nearby objects.
- The DC power wire must be fused at the battery positive (+) terminal connection. Before making or breaking power connections at the amplifier power terminals, disconnect the DC power wire at the battery end.
- The battery of the car audio system must be disconnected until the entire wiring and installation is completed.

# CONTROL PANEL LAYOUT

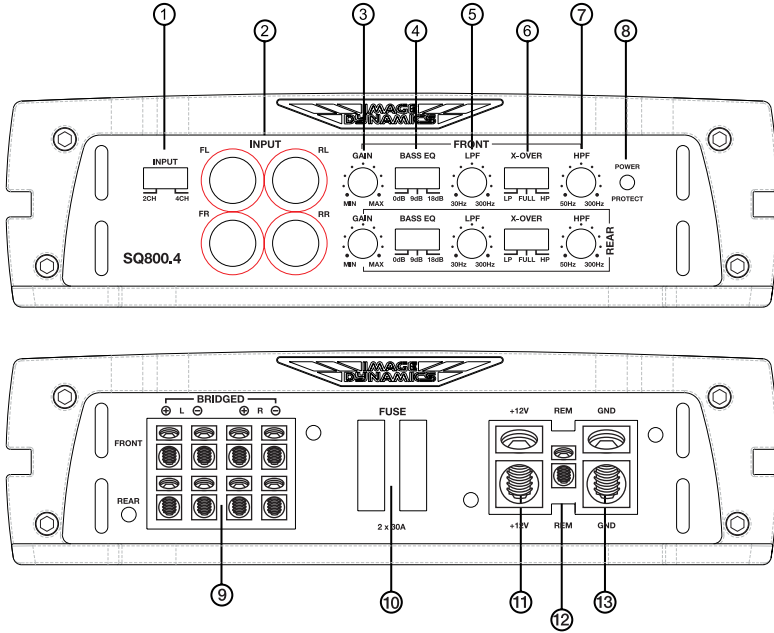

Fig.2 Panel Layout

**NOTE:** Panel Layout and Controls may differ by model.

### 1. Line Input Switch (SQ800.4 only)

This switch will let you use a single pair of RCA inputs to run all 4 channels of the amplifier or have 2 pair of RCA inputs to run all 4 channels of the amplifier separately. The SQ1400.5 has a subwoofer input selector button that allows the input signal to be taken from the Rear Channel if selected. If the subwoofer input button is selected at the Sub position, then a dedicated input needs to be used.

### 2. Line INPUT (RCA) Jacks

These RCA style input jacks are for use with source units that have RCA line level outputs. A source unit with a minimum of 250mV is required for proper operation. However, this input will accept levels up to 10 Vrms.

### 3. FRONT and REAR GAIN Control

This control is used to match the input sensitivity of the amplifier to the particular source unit that you are using.

### 4. FRONT and REAR BASS EQ Switch for 0dB/9dB/18dB (SQ800.4 only)

This equalization circuit is used to enhance the low frequency response of the vehicles interior and only works with LFP setting ON. Selectable to 0dB (flat) or 9dB to 18dB of boost centered at 45Hz, the BASS EQ switch can be selected to meet your own personal tastes. Remember, more is not always better.

#### **5. FRONT and REAR LPF (Low Pass Filter) 40 Click Detent Control**

This control is continuously adjustable from 30Hz through 300Hz at 12dB per octave.

#### **6. FRONT and REAR X-OVER Switch for LPF/FULL/HPF (SQ800.4 only)**

Activates the built-in electronic crossover network. Works in conjunction with the LPF and HPF adjustable controls. When set to FULL, the two variable controls marked HPF and LPF have no effect on the amplifiers output.

#### **7. FRONT and REAR HPF (High Pass Filter) 40 Click Detent Control**

This control is continuously adjustable from 50Hz through 300Hz at 12dB per octave.

#### **8. POWER/STATUS Indicator**

The clear LED lights Blue when the power is on—or turns Red constantly when the built-in protection circuitry is activated. Red indicates a problem with the system in relation to the amplifier. (See Troubleshooting Tips on pg 25)

#### **9. SPEAKER Output Terminals**

This specially tooled solderless terminal block is designed to accommodate up to 10-gauge speaker wire. Please refer to the wiring diagrams in this manual and be sure to observe speaker polarity and impedance throughout the system.

#### **10. FUSE(S)**

For convenience most Image Dynamics amplifiers utilize common automotive ATC type fuses. For continued protection in the event that a fuse blows, replace the fuse only with the same value (see specification table). CAUTION: These power fuses on the amplifier chassis are for protecting the amp against overdrive. To protect the vehicles electrical system, an additional fuse should be used within 18-inches of the battery on the 12V+ cable.

---

SQ1400.5 100A (Requires external fuse - not supplied)

NOTE: Due to space limitations, the SQ1400.5 does NOT use chassis mounted protective fuses. Therefore you must add a fuse and fuse holder (not included) rated at 100A for each SQ1400.5 installed.

---

#### **11. BATT+ (Power Input Connection)**

This solderless terminal is the main power input for the amplifier and must be connected directly to the 12-volt Positive (+) terminal of the car battery. The terminal can accept up to 4-gauge wire (see Power Cable Selection Chart for the minimum recommended wire gauges).

#### **12. REM (Remote Input Connection)**

All Image Dynamics amplifiers can be turned on by applying 12 volts to this terminal. This can be found on the rear of the source unit in the form of a remote output. If this is not available you can wire to the ACC position on the key. An 18 gauge wire is sufficient to run the REMOTE.

#### **13. GND (Ground Input Connection)**

A good quality ground is required for your Image Dynamics amplifier to operate at peak performance. A short length of cable the same gauge as the Power cable should be used to attach the Ground terminal directly to the chassis of the vehicle. Make sure that all of the paint is sanded or scraped away to ensure a good ground connection.



# POWER WIRING AND SIGNAL CONNECTIONS

**\*\*\* WARNING \*\*\***

**Disconnect the negative (-) battery terminal before you start any wiring work! The battery of your car audio system must be disconnected until the entire wiring installation is completed.**

Your Image Dynamics amplifier requires unrestricted current to deliver peak performance, so do not “starve” your amplifier by using small power cable. Using under sized power cable can result in unnecessary over-heating of the amplifier, distortion at high volume levels and might even cause the thermal protection circuitry to shut-off the amplifier. Remember, bigger wire is better!

- Use rubber grommets when running cables through any metal or sharp plastic to prevent accidental shorting or shearing. Make sure the cables do not interfere with normal operation of the vehicle.
- The audio signal cables (RCA interconnects) should be kept far away from any potential sources of electrical interference such as electronic vehicle management systems (relays, engine computers etc.), wiring harnesses, fuel pumps etc.

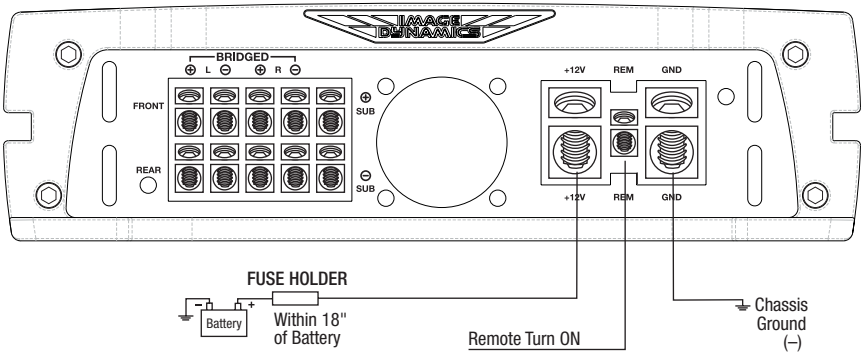

Fig.3 SQ1400.5 Power Input Connection

These amplifiers are designed to work within a 10 to 16 volt DC range. Before any wires are connected, the vehicles electrical system should be checked for correct voltage supply with the help of a voltmeter.

First, check the voltage at the battery with the ignition in the OFF position. The voltmeter should read no less than 12V. If your vehicles electrical system is not up to these specifications, we recommend having it checked by an auto electrician before any further installation. Once the vehicle is checked, make certain the correct cable gauge is used. The SQ amplifier terminals are capable of accepting up to 4 gauge power and ground cable. We recommend using as large a gauge cable as possible, use the Power Cable Selection Chart to calculate the correct power wire size for your application.

## POWER WIRING

### BATT+ (Power)

This amplifier should be wired directly to the vehicle battery using the appropriate size cable. Start at the vehicle battery and run the power cable through to the amplifier. Avoid running the power cable over engine components and near heater cores. The use of an in-line fuse or circuit breaker is a must; this will prevent the risk of a potential fire caused by a short in your power cable. Connect the fuse holder or circuit breaker as close to the battery positive (+) terminal as possible (within 18" from the battery). This fuse or circuit breaker should be no greater then the sum of the fuses found on the chassis of your amplifier (also see specifications chart). You may now connect the cable to the battery, but remember to leave the fuse out or circuit breaker "off" until all other cable connections are made.

### GND (Ground)

When grounding your amplifier, locate a metal area close to the amplifier that is good source of ground (preferable the floor pan). Use a short length of cable the same gauge as your power cable. Once again, investigate the area you wish to use for electrical wires, vacuum lines, and brake or fuel lines. Use either a wire brush or sandpaper to eliminate unwanted paint for better contact of the ground.

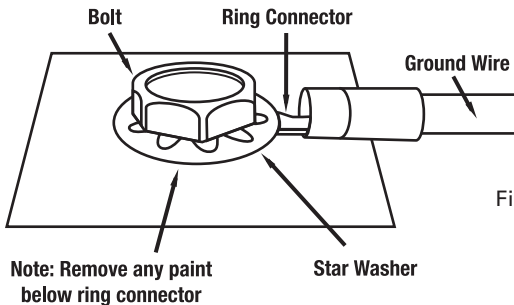

Fig.4 Ground Connection

Secure the ground cable to the body using a bolt, star washer and nut. Spread silicon over the screw and bare metal to prevent rust and possible water leaks.

---

NOTE: The Ground must be capable of carrying the same amount of current as the positive wire.

---

Now it's time to connect the power and ground cables to the amplifier. Cut both cables to length. Strip off 1/2 inch (12mm) of the insulation so that the bare wire fits all the way in the terminal block on the side panel of the amplifier, seating it firmly so no bare wire is exposed. Use a screw driver to loosen the BATT+ and the GND connection on the amplifier. Insert the ground first, and then the +12V and please make sure that you place them into the correctly marked terminals. Hand tighten the set screws and make sure the connection is secure to prevent possible arcing due to loose screws.

**REM (Remote Trigger)**

This terminal must be connected to a switched +12V source. Typically, a remote turn-on lead is provided at the source unit that will turn on and off the amplifier in correspondence with the source. If this lead is not at the source unit, then a switched +12V supply must be used, like the ACC, +12V.

Run a minimum of 18 gauge wire from the amplifier location to the source of the switched +12V lead. If possible, route this wire on the same side of the vehicle as your power cable. Connect the source remote output to the wire. Go back to the amplifier and cut the wire to length. Loosen the screw terminal marked REM on the amplifier. Insert the stripped (bare) portion of the wire into the terminal and tighten the screw securely.

## CONNECTIONS TO AMPLIFIER FOR BATT+ , GND, REM AND SPEAKERS

Your Image Dynamics amplifier features specially tooled solderless terminals for Power (BATT+), Ground (GND), Remote (REM) and Speaker connections. For maximum transfer of Voltage and Signal the bare wire needs to be inserted as far as possible into the terminal before tightening the set screw and make sure the connection is secure to prevent possible arcing due to loose screws.

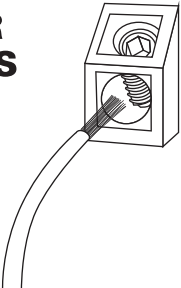
A line drawing showing a wire with a stripped end being inserted into a terminal block. The terminal block has a set screw on top. The wire is shown from a side perspective, curving upwards into the terminal.

---

**NOTE:** It is highly recommended that an Allen wrench is used to tighten the set screws in the terminal blocks by hand and NOT a power drill. This will prevent stripping or other possible damage to the amplifier.

---

## RCA INTERCONNECT (SQ800.4)

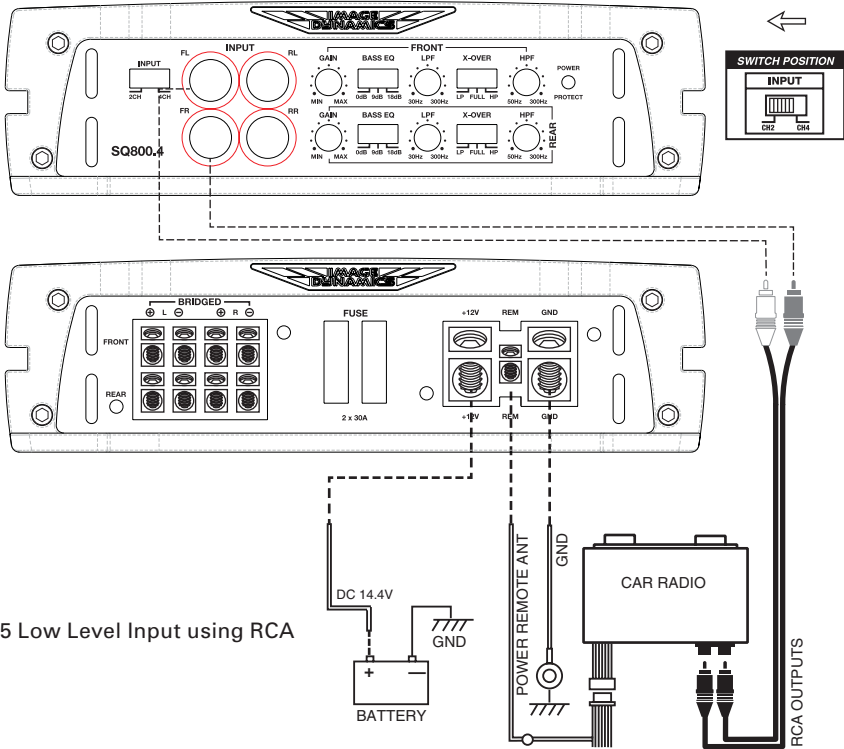

Fig.5 Low Level Input using RCA

**Low Level Input** - Choose the correct length and style of RCA interconnects for your needs. Always use high quality RCA audio cables (not supplied) for signal connections—those with multiple layers of shielding or a twisted pair variety for better noise rejection.

Be extra careful when routing your RCA audio interconnect cables. Car environments are notorious for poorly insulated wires. This means that hiss, engine noise, and fan noise can easily be picked up through RCA cables if run incorrectly.

Make sure that the cables for power and audio signal are not on the same side of the vehicle and that they do not cross each other; this will help reduce any noise that may radiate from the power cable and the signal cable. If an audio cable is too close to a power cable, it may pick up the magnetic field generated by the power cable, which could lead to a loss of quality in your signal.

# RCA INTERCONNECT (SQ800.4)

## Single RCA OUT

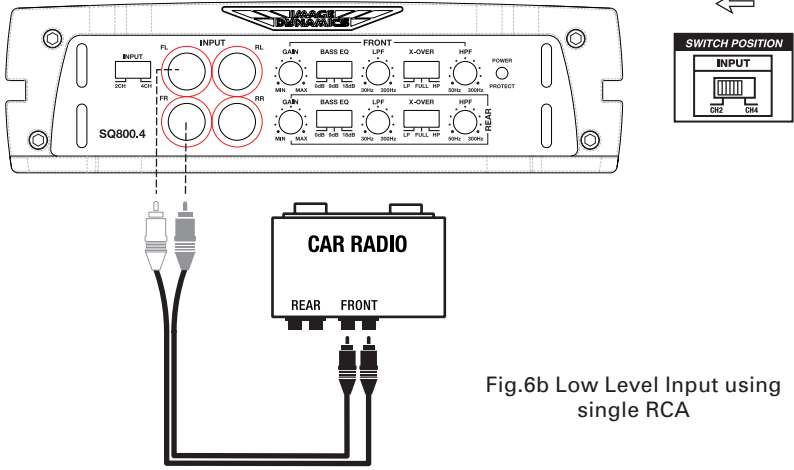

Fig.6b Low Level Input using single RCA

## Dual RCA OUT (Front and Rear)

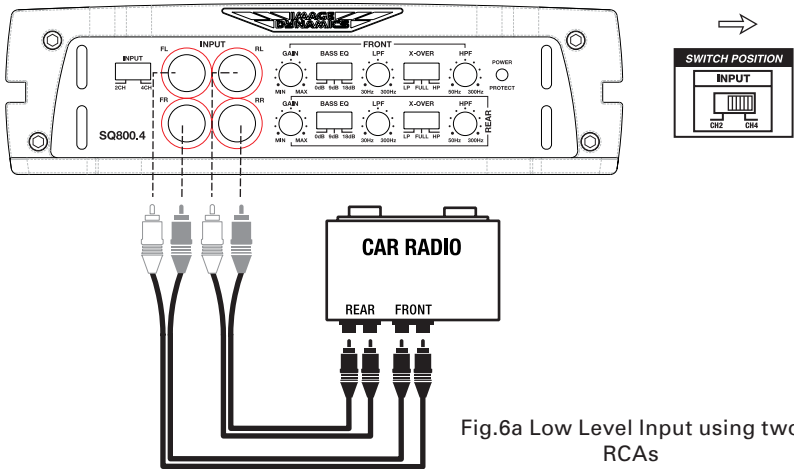

Fig.6a Low Level Input using two RCAs

# SQ1400.5

## Single RCA OUT

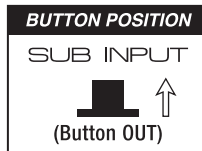
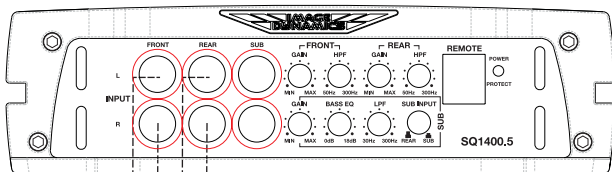
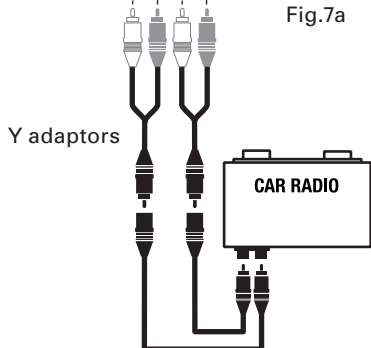

Fig.7a



Single RCA Output on the Radio (Rear only). In the event the car radio (head unit) you are using has only 1-set of RCA preamp outputs, you will need to split the signal using "Y" adaptors on the Right and Left channels as shown above. Since the radio's 2V (or possibly lower) pre out signal is split between 3 sets of inputs, the GAIN controls will need to be set considerably higher to maximize the amplifiers output. By doing this you will lose the Front to Rear fader capability as only the Rear RCA is being used.

## Dual RCA OUT (Front and Rear)

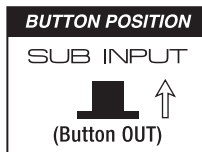
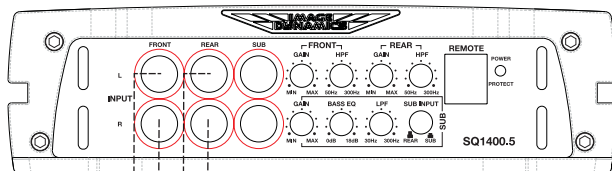
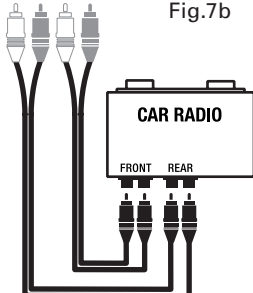

Fig.7b



Dual RCA Output from the Radio (Front and Rear)

If the car radio (head unit) you are using has 2-sets of RCA preamp outputs you will retain the full balance and fade capabilities of your radio. With the SUB INPUT button "out" the subwoofer is unaffected by fade Front to Rear.

## SQ1400.5 (continued)

### Three RCA OUT (Front and Rear plus Subwoofer)

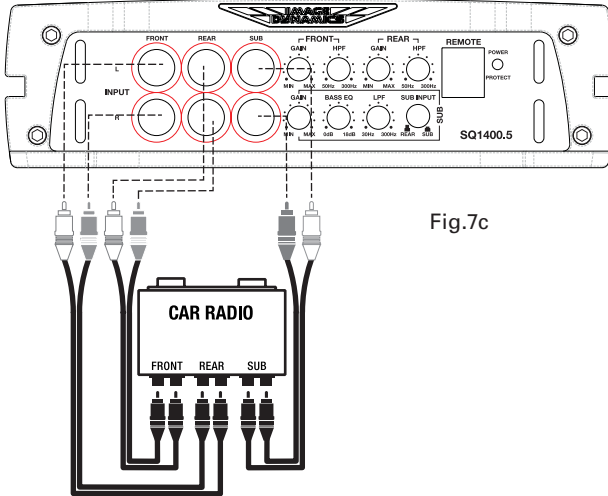
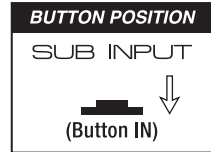

Fig.7c



### Three RCA Outputs from the Radio (Front and Rear plus Subwoofer)

This is the optimum configuration for this amplifier by providing 3-sets of discrete signal to the preamp. It will also offer the most flexibility in tuning the system.

# SET UP ADJUSTMENTS

## INPUT Gain Adjustment



Fig.9 GAIN Control

This control allows you to match the input level of the amplifier to the output level of your head unit. Matching the input can be accomplished in three simple steps:

1. Set the volume of GAIN on the amplifier to Min (completely counter clock wise).
2. Turn on the head unit and adjust volume to 2/3 maximum, and set the BASS and TREBLE to zero.
3. Adjust the GAIN control clockwise until the sound just begins to distort, then back off slightly to cut distortion and operate at optimum gain.

Remember, the GAIN control is not a volume control. Ignoring the three steps above may leave you with damaged speaker and/or a damaged amplifier.

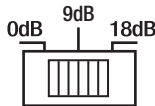

Fig.10 Bass EQ Control

## BASS EQ Switch

This special feature is designed to provide you more powerful sound quality, and it allows you to boost the real Bass EQ up +18dB. The level of boost can be set to either 0 (no boost), +9dB or +18dB. Keep in mind that more is not always better! Setting the control to the max (18dB) can stress the amplifier and the speakers which may result in damage to your system.



Fig.11 High Pass Control (HPF)

## HPF (High Pass Filter) 40 Click Detent Control

When you are using coaxial or component speaker system, this allows you to adjust high-pass X-over frequency from 50Hz to 300Hz. To get better sound quality from coaxial or component speaker system, we recommend the frequency should be higher than 80Hz. Make sure the X-OVER switch is positioned at "HPF". See the charts on pages 22-24 to set the High Pass Filter to the precise frequency for your particular amplifier.





Fig.12 Low Pass Control (LPF)

**LPF (Low Pass Filter) 40 Click Detent Control**

Using this potentiometer, adjust the LPF frequency for your subwoofer speaker(s) operation. The X-OVER switch position should be at "LPF". Use the enclosed chart to precisely dial in desired frequency. See the charts on pages 22-24 to set the Low Pass Filter to the precise frequency for your particular amplifier.

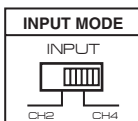
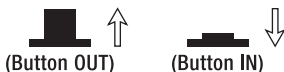

Fig.13 2-4 Channel Input Mode

**Input Mode Switch (SQ800.4)**

Matches the input from the Source Unit to that of the amplifier, either 2 or 4 Channel. This eliminates the use of "Y" adapters and provides a cleaner input signal.

**SPECIAL CONTROLS FOR THE SQ1400.5** The following instructions apply to the model SQ1400.5 only. You will not find these controls on any of the other models in this series.



**Sub Input Button**

The SQ1400.5 is a 5-channel amplifier that incorporates an advanced crossover network and a Subwoofer Remote Level control. You are able to select which of the 4 inputs that subwoofer signal is sourced to. With the Subwoofer Source button in the out position the subwoofer will receive its signal from a sum of the FRONT/REAR inputs. With the button in, the subwoofer signal will come from the SUB inputs.



**BASS EQ Variable Control**

This special feature is designed to provide you more powerful sound quality, and it allows you to adjust the Bass EQ up to 18dB at 45Hz. Keep in mind more is not always better. Setting the control to the max (18dB) may stress the amplifier and woofer and could result in damage.

# SPEAKER WIRING AND CONFIGURATIONS

## Speaker Load

Keep in mind your Image Dynamics amplifier is a high power amplifier and not a high current amplifier. In other words this amplifier requires a minimum impedance of 2 ohms STEREO or 4 ohms bridged MONO to operate trouble free. Lower impedance will send the amplifier into protection and possibly damage the electronics inside and void the warranty.

The SQ1400.5 is stable to 2-ohms on the SUB channel.

---

NOTE: Know your total impedance load before you make any connections.

---

## Speaker Wiring

Choose the correct speaker wire for your application. Most applications will require a minimum of 16 gauge wire. Route these using the same precautions as you did when you ran the power cable. Terminate these wires at the speaker end using insulated speaker terminals (not supplied) or by soldering the connection. Make sure the speaker connections are positive-to-positive and negative-to-negative. At the amplifier end, it is very important that the wires are making solid contact. Strip the wires insulation back approximately 1/2 inch (12mm) and insert the wires into the appropriate openings while being careful there are no loose or frayed strands of wire straying from the terminal. Check to make sure you've maintained proper polarity and balance.

---

### CAUTION

Maintaining proper impedance is critical when wiring the Full Range Digital model amplifiers. Improper wiring can cause severe damage to BOTH the woofer and the amplifier. Detailed wiring diagrams are supplied with all Image Dynamics woofers.

IF YOU ARE NOT EXPERIENCED OR UNCOMFORTABLE READING THE WIRING DIAGRAMS CONSULT YOUR AUTHORIZED Image Dynamics DEALER BEFORE YOU ATTEMPT TO WIRE THE SYSTEM.

---

# SPEAKER OUTPUT CONNECTIONS 4 CHANNEL MODEL (SQ800.4)

## 3. 4-Channel Speaker Output Connection

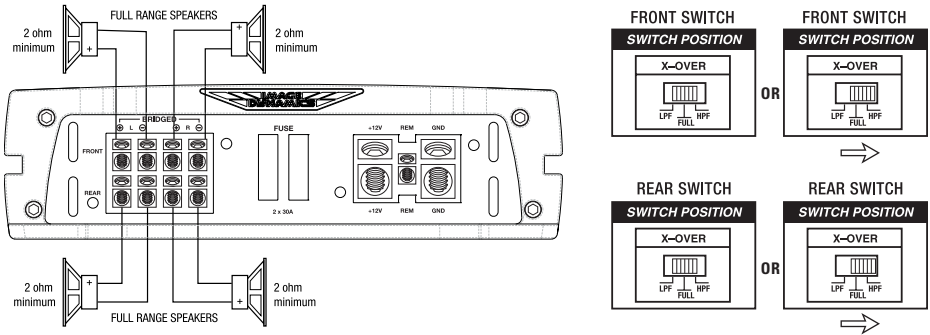

Fig.16 4-CH Speaker Connection / 2 ohms minimum

## 4. 3-Channel Stereo/Mono Speaker Output Connection

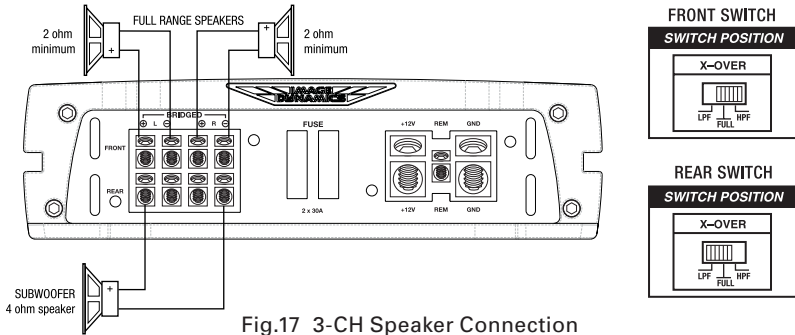

Fig.17 3-CH Speaker Connection

## 5. 2-Channel (Bridged Mode) Speaker Output Connection

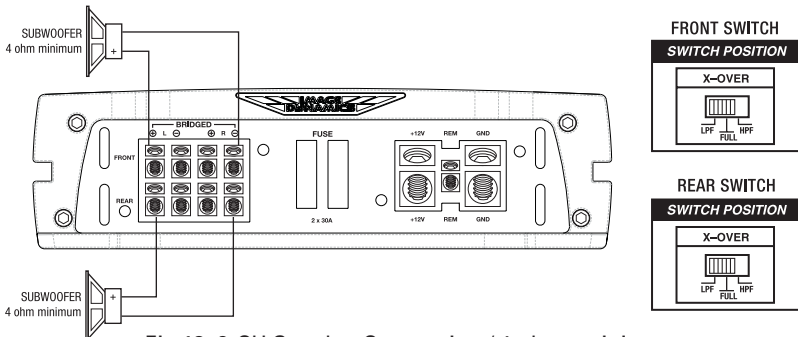

Fig.18 2-CH Speaker Connection / 4 ohms minimum

# SPEAKER OUTPUT CONNECTIONS 5 CHANNEL MODEL (SQ1400.5)

## 6. 5-Channel Speaker Output Connection

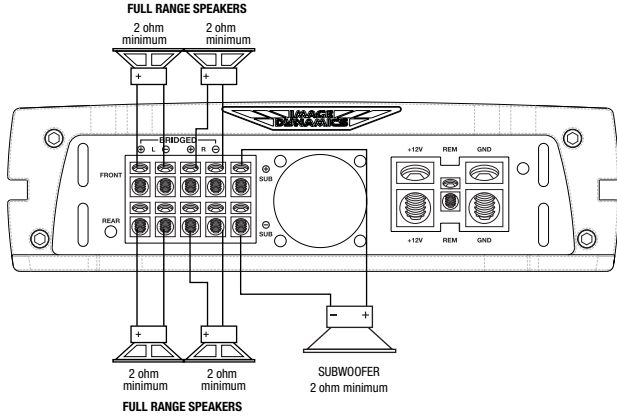

Fig.19 5-CH Speaker Connection / 2 ohms minimum

## 7. 3-Channel Speaker Output Connection

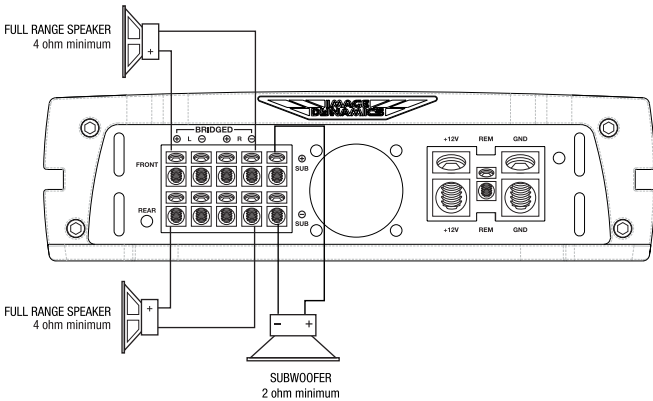

Fig.20 3-CH Speaker Connection

## RECOMMENDED WIRE SIZES

<b>Power Cable Selection Chart</b>							
<b>Fuse Total</b>	<b>4Ft</b>	<b>4-7Ft</b>	<b>7-10Ft</b>	<b>10-13Ft</b>	<b>13-16 Ft</b>	<b>16-19 Ft</b>	<b>19-22 Ft</b>
<b>In Amperes</b>	<b>Length of Wire/Gauge</b>						
150A - 200A	2 GA	2 GA	2 GA	*1/0*	*1/0*	*1/0*	*1/0*
125A - 150A	4 GA	4 GA	4 GA	4 GA	2 GA	2 GA	2 GA
105A - 125A	8 GA	8 GA	8 GA	4 GA	4 GA	4 GA	2 GA
85A - 105A	8 GA	8 GA	8 GA	4 GA	4 GA	4 GA	4 GA
65A - 85A	10 GA	8 GA	8 GA	8 GA	4 GA	4 GA	4 GA
50A - 65A	10 GA	10 GA	8 GA	8 GA	8 GA	8 GA	8 GA
35A - 50A	10 GA	10 GA	10 GA	8 GA	8 GA	8 GA	8 GA
25A - 35A	10GA	10GA	10GA	10GA	8GA	8GA	8GA

**PERSONAL NOTES:**

Name: \_\_\_\_\_

Date Purchased: \_\_\_\_\_

Dealer: \_\_\_\_\_

Installed By: \_\_\_\_\_

Model: \_\_\_\_\_

Serial Number: \_\_\_\_\_

Miscellaneous: \_\_\_\_\_

This manual is the exclusive property of Image Dynamics USA, Inc. Any reproduction of this manual, or use other than its intentions is strictly prohibited without the express consent of Image Dynamics USA, Inc. © Copyright 2016 Image Dynamics USA, Inc.

## 40 CLICK PRECISION ROTARY CONTROLS

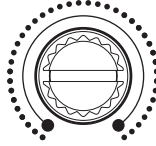

These controls allow precise setting of the electronic crossover settings on the amplifier, thus taking the guesswork out of tuning your speakers. Using a small slotted screwdriver make sure the controls are turned all the way to the left (counter clockwise). Refer to the chart and count the clicks (advancing one detent at a time clockwise) until you have reached the desired frequency.

This precise method of setting the crossover controls is available for the LPF and HPF features on the 4-channel amplifier. It is available for the HPF and LPF/SUB features on the 5-channel amplifier.

---

**NOTE:** Select the appropriate chart for your particular model amplifier

---

## SQ1400.5

<b>Click Position</b>	<b>FRONT High Pass Freq</b>	<b>REAR High Pass Freq</b>	<b>SUB Low Pass Freq</b>	<b>Bass Freq</b>
1	50Hz	50Hz	30Hz	0 dB
2	50Hz	54Hz	30Hz	0 dB
3	50Hz	54Hz	30Hz	0 dB
4	50Hz	55Hz	30Hz	0.1 dB
5	50Hz	55Hz	30Hz	0.2 dB
6	50Hz	56Hz	31Hz	0.2 dB
7	53Hz	58Hz	33Hz	0.4 dB
8	57Hz	62Hz	35Hz	0.6 dB
9	60Hz	67Hz	38Hz	0.8 dB
10	65Hz	73Hz	41Hz	1.2 dB
11	72Hz	80Hz	45Hz	1.6 dB
12	78Hz	86Hz	50Hz	1.8 dB
13	85Hz	93Hz	55Hz	2.25 dB
14	94Hz	103Hz	61Hz	2.6 dB
15	104Hz	115Hz	68Hz	2.8 dB
16	117Hz	128Hz	78Hz	3.1 dB
17	133Hz	146Hz	90Hz	3.3 dB
18	151Hz	166Hz	102Hz	3.6 dB
19	168Hz	186Hz	110Hz	3.9 dB
20	175Hz	191Hz	124Hz	4.2 dB
21	178Hz	192Hz	128Hz	4.4 dB
22	187Hz	199Hz	132Hz	4.8 dB
23	190Hz	204Hz	137Hz	5.2 dB
24	196Hz	207Hz	143Hz	5.6 dB
25	204Hz	212Hz	150Hz	6 dB
26	212Hz	217Hz	160Hz	6.5 dB
27	220Hz	223Hz	166Hz	7.2 dB
28	230Hz	229Hz	176Hz	8 dB
29	238Hz	234Hz	187Hz	9 dB
30	250Hz	245Hz	200Hz	10.4 dB
31	262Hz	252Hz	214Hz	11.6 dB
32	268Hz	264Hz	231Hz	12.2 dB
33	270Hz	267Hz	235Hz	13 dB
34	272Hz	272Hz	243Hz	13.6 dB
35	272Hz	274Hz	250Hz	14 dB
36	275Hz	280Hz	257Hz	14.8 dB
37	278Hz	285Hz	268Hz	15.5 dB
38	282Hz	290Hz	277Hz	16.2 dB
39	285Hz	291Hz	283Hz	16.7 dB
40	300Hz	300Hz	300Hz	18 dB

## SQ800.4

<b>Click Position</b>	<b>FRONT High Pass Freq</b>	<b>FRONT Low Pass Freq</b>	<b>REAR High Pass Freq</b>	<b>REAR Low Pass Freq</b>
1	40Hz	30Hz	40Hz	30Hz
2	40Hz	32Hz	40Hz	35Hz
3	41Hz	40Hz	41Hz	40Hz
4	41Hz	46Hz	42Hz	45Hz
5	41Hz	47Hz	44Hz	45Hz
6	41Hz	48Hz	44Hz	46Hz
7	42Hz	50Hz	45Hz	50Hz
8	44Hz	54Hz	47Hz	53Hz
9	46Hz	60Hz	50Hz	57Hz
10	50Hz	65Hz	54Hz	63Hz
11	54Hz	71Hz	59Hz	68Hz
12	60Hz	77Hz	65Hz	74Hz
13	65Hz	84Hz	72Hz	81Hz
14	72Hz	93Hz	79Hz	90Hz
15	80Hz	103Hz	88Hz	100Hz
16	91Hz	117Hz	99Hz	113Hz
17	103Hz	135Hz	113Hz	129Hz
18	119Hz	180Hz	133Hz	147Hz
19	136Hz	188Hz	153Hz	174Hz
20	158Hz	194Hz	180Hz	186Hz
21	165Hz	207Hz	186Hz	193Hz
22	171Hz	212Hz	192Hz	201Hz
23	178Hz	221Hz	197Hz	209Hz
24	188Hz	232Hz	204Hz	218Hz
25	199Hz	243Hz	213Hz	229Hz
26	206Hz	262Hz	222Hz	238Hz
27	217Hz	272Hz	233Hz	250Hz
28	226Hz	289Hz	242Hz	266Hz
29	239Hz	305Hz	254Hz	294Hz
30	254Hz	327Hz	271Hz	300Hz
31	273Hz	356Hz	286Hz	323Hz
32	298Hz	365Hz	300Hz	346Hz
33	317Hz	376Hz	322Hz	357Hz
34	324Hz	387Hz	332Hz	369Hz
35	335Hz	397Hz	342Hz	377Hz
36	340Hz	408Hz	349Hz	389Hz
37	352Hz	420Hz	360Hz	398Hz
38	361Hz	432Hz	368Hz	414Hz
39	376Hz	435Hz	380Hz	425Hz
40	400Hz	440Hz	400Hz	440Hz



## TROUBLESHOOTING TIPS

Problem	Solution
<b>Power LED not ON</b>	With a Volt Ohm Meter (VOM) check: <ul style="list-style-type: none"> <li>• +12 Volt power terminal (should read +12 to +16VDC)</li> <li>• Remote turn-on terminal (should read +12 to +16VDC)</li> <li>• Ground Terminal</li> </ul>
<b>Power LED lights BLUE, no output</b>	<ul style="list-style-type: none"> <li>• Check RCA connections</li> <li>• Test speaker outputs with known good speaker</li> <li>• Substitute known good Source Unit</li> <li>• Check for signal on the RCA cable with VOM in AC position</li> </ul>
<b>Power LED lights BLUE, amp plays at very low volume on one or more outputs</b>	<ul style="list-style-type: none"> <li>• Short circuit protection is engaged. Check for speaker wires shorted to each other or the vehicle chassis. Speakers operating below the minimum impedance can cause this to occur.</li> </ul>
<b>Red Status Protection LED is ON, no output and</b> <b>1. Amp is VERY HOT</b>  <b>2. Amp shuts down ONLY when the vehicle is running</b>	<ul style="list-style-type: none"> <li>• Thermal protection is engaged. Check for proper impedance at speaker terminals. Also check for adequate air flow around the amplifier.</li> <li>• Voltage protection engaged. Voltage to the amp is not within the 10-16 VDC operating range. Have the battery/charging system inspected.</li> </ul>
<b>Alternator noise (varies with RPM)</b>	<ul style="list-style-type: none"> <li>• Check for damaged RCA cable.</li> <li>• Check routing of RCA cable</li> <li>• Check Source Unit for good ground</li> <li>• Check amp gain setting, turn down if set too high</li> </ul>
<b>Poor Bass Response</b>	<ul style="list-style-type: none"> <li>• Check speaker polarity, reverse the connection of one speaker only.</li> </ul>

---

NOTE: If the Status L.E.D. is activated and glows RED with no speakers connected to the amplifier, and all the power connections are correct, this would indicate an internal problem with the amplifier. Contact Image Dynamics USA or your local dealer.

---

# SPECIFICATIONS

Four Channel Model	SQ800.4
4 Ohms Power (Watts)	100 x 4
2 Ohms Power (Watts)	200 x 4
4 Ohms Mono Power (Watts)	400 x 2
Peak Music Power (Watts)	800
THD @ RMS Power	< 0.1%
Frequency Response	10Hz - 30kHz
S/N Ratio (EIA Rated)	>95dB
Input Sensitivity	250mV - 10.0 volts
Crossover Slope	12dB
High-Pass Crossover Freq. (Hz)	50Hz - 300Hz
Low-Pass Crossover Freq. (Hz)	30Hz - 300Hz
Selectable Subwoofer EQ	0 / 9dB / 18dB
Subwoofer EQ Freq.	45Hz
Fuses/ ATC Style	30A x 2
Dimension ( 267 x 184 x 51mm )	10.5" x 7.25" x 2.0"

Five Channel Model	SQ1400.5
4 Ohms Stereo Power (Watts)	100 x 4 + 300 x 1
2 Ohms Stereo Power (Watts)	200 x 4 + 600 x 1
4 Ohms Bridged Power (Watts)	400 x 2 + 600 x 1 (2-Ohm)
Peak Music Power (Watts)	1400
THD @ RMS Power	< 0.1%
Frequency Response	10Hz - 30kHz
S/N Ratio (EIA Rated)	> 95dB
Input Sensitivity	250mV - 10.0 volts
Crossover Slope	12dB
High-Pass Crossover Freq. (Hz)	50Hz - 300Hz
Low-Pass Crossover Freq. (Hz / Sub Out only)	30Hz - 300Hz
Variable Subwoofer EQ	0 - 18dB
Subwoofer EQ Freq.	45Hz
Fuse Rating / Style	100A* <b>CAUTION (READ NOTE *)</b>
Dimension ( 338 x 184 x 51mm )	13.3" x 7.25" x 2.0"

### Important Notes:

- Due to continuing improvements these specifications are subject to change without any notice.
- Do not attempt to fix or repair this unit. Unauthorized repairs will void the manufacturer's warranty.

**\*FUSE NOTE:** Due to space limitations, the SQ1400.5 does NOT use chassis mounted protective fuses.

Therefore you must add a fuse and fuse holder (not included) rated at 100A for each SQ1400.5 installed.

# IMAGE DYNAMICS ELECTRONICS LIMITED WARRANTY POLICY

Image Dynamics USA, Inc. offers limited warranty on Image Dynamics products under normal use on the following terms:

Image Dynamics Amplifiers are to be free of defects in material and workmanship for a period of one (1) year.

This warranty applies only to Image Dynamics products sold to consumers by Authorized Image Dynamics Dealers in the United States of America. Products purchased by consumers from a Image Dynamics dealer in another country are covered only by that country's Distributor and not by Image Dynamics USA.

This warranty covers only the original purchaser of Image Dynamics product. In order to receive service, the purchaser must provide Image Dynamics with the receipt stating the consumer name, dealer, product and date of purchase.

Products found to be defective during the warranty period will be repaired or replaced (with a product deemed to be equivalent) at Image Dynamics's discretion and will not be liable for incidental or consequential damages. Image Dynamics will not warranty this product under the following situations:

- Amplifiers received with apparent rust or corrosion
- Any evidence of liquid damage or exposure to excessive heat
- Attempted repairs or alterations of any nature
- Product that has not been installed according to this owners manual

Any implied warranties including warranties of fitness for use and merchantability are limited in duration to the period of the express warranty set forth above. Some states do not allow limitations on the length of an implied warranty, so this limitation may not apply. No person is authorized to assume for Image Dynamics any other liability in connection with the sale of this product.

Please call (909) 930-1377 for Image Dynamics Customer Service. You must obtain an RA# (Return Authorization Number) to return any product to Image Dynamics. The RA number must be prominently marked on the outside of the shipping carton or the delivery will be refused. Please pack your return carefully; we are not responsible for items damaged in shipping. Return the defective product along with a copy of the original dated retail sales receipt, plus \$12.00 for handling and diagnostic evaluation to:

Image Dynamics USA, Inc.,  
Attn: Returns (RA#\_\_\_\_\_)  
2133 S. Green Privado, Ontario, CA 91761

Residents of HI, AK and US territories will be charged for return shipping. All inquires regarding service and warranty should be sent to the above address.

Removed or altered serial numbers will void this warranty

Image Dynamics USA, Inc.  
2133 S. Green Privado – Ontario, CA 91761  
Tel. (909) 930-1377 – Fax (866) 239-4399  
[www.imagedynamicsusa.net](http://www.imagedynamicsusa.net)