



## IDQ SERIES SUBWOOFERS V4

IDQ8V4 D4/D2

IDQ10V4 D4/D2

IDQ12V4 D4/D2



## OWNERS MANUAL

---

Please read through this manual to familiarize yourself with your new subwoofer. Should your Image Dynamics subwoofer ever require service, you will need to have the original dated receipt.



---

Δ Caution Δ

High powered audio systems in a vehicle are capable of generating higher than "Live Concert" levels of sound pressure. Continued exposure to excessively high volume sound levels could cause hearing loss or damage. Also, operation of a motor vehicle while listening to audio equipment at high volume levels may impair your ability to hear external sounds such as horns, warning signals, or emergency vehicles—thus creating a potential traffic hazard. In the interest of safety, Image Dynamics USA highly recommends listening at lower volume levels when driving.

---

# IMAGE DYNAMICS IDQ SERIES SUBWOOFERS

**High Excursion Design** allows acoustically linear bass output at all rated power levels.

**Parabolic Santoprene Surround** to ensure cone linearity and control.

**Poly Mica Cone** for strong distortion free bass reproduction while still reproducing all of the musical nuances.

**Nomex Spider** for consistent control throughout the piston range and life of the woofer.

**Poly Carbonate Neck Joint** allows the woofer to handle more raw power without any mechanical failure or flex while isolating heat from the BASV voice coil former from the cone.

**American Made Flat Wound Extended Voice Coil** gives our woofers higher magnetic flux (strength) and more voice coil "traction" in the magnetic gap with over 1.813" of linear travel in the magnetic gap.

**Extended Y-35 Motor Structure** allows the voice coil to move freely without any mechanical bottoming out while producing a very powerful flux field.

**Field Replaceable Cone Assembly** can be changed in 10 minutes with only 16 screws and alignment shims included with the recone kit.



# WIRING GUIDELINES

It is highly recommended that you seek an authorized Image Dynamics dealer to properly setup, wire and install your woofers for maximum performance.

There are multiple ways to wire your woofers depending on your amplifier and system configuration. The use of multiple voice coils offers you more versatility in system configuration. It is important to know the limits of your amplifier to optimize its performance. It is always better to use your subwoofer in a mono / bridged mode if your amplifier has the capabilities. There are basically four different types of wiring configurations: Series, Parallel, Series-Parallel or Parallel-Parallel. It is possible to change the impedance or load by how the speakers are to be wired and by the quantity of woofers used.

## DUAL VOICE COIL WIRING (DUAL 4 OHM)

### PARALLEL

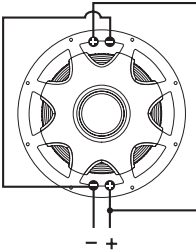

Amplifier

Parallel wiring a dual 4 ohm sub = 2 ohm

### SERIES

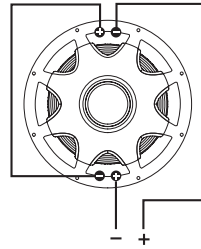

Amplifier

Series wiring a dual 4 ohm sub = 8 ohm

### PARALLEL-PARALLEL

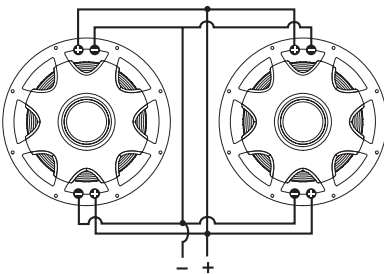

Amplifier

Parallel-Parallel wiring two dual 4 ohm subs = 1 ohm

### SERIES PARALLEL

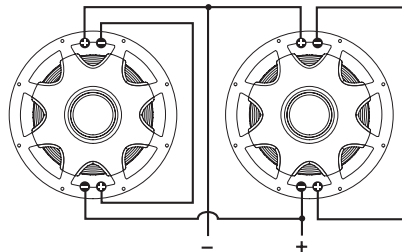

Amplifier

Series-Parallel wiring two dual 4 ohm subs = 4 ohm

# DUAL VOICE COIL WIRING (DUAL 2 OHM)

## PARALLEL

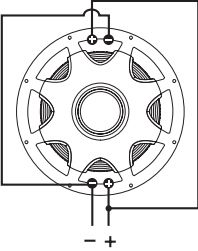

**Amplifier**

Parallel wiring a dual 2 ohm sub = 1 ohm

## SERIES

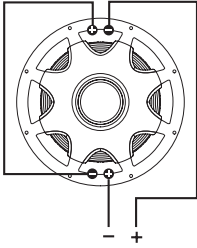

**Amplifier**

Series wiring a dual 2 ohm sub = 4 ohm

## PARALLEL-PARALLEL

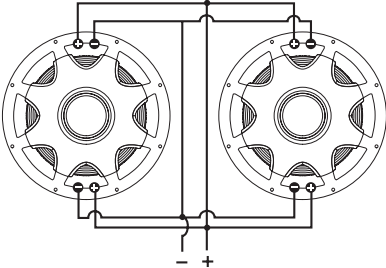

**Amplifier**

Parallel-Parallel wiring two dual 2 ohm subs = 1/2 ohm

## SERIES PARALLEL

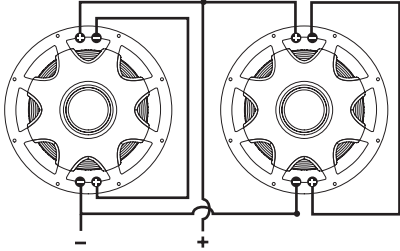

**Amplifier**

Series-Parallel wiring two dual 2 ohm subs = 2 ohm

---

**NOTE:** Never connect only one coil of a Dual Voice Coil (DVC) speaker. BOTH voice coils must be connected to the amplifier

---

## TIPS TO GET THE MOST OUT OF YOUR IMAGE DYNAMICS SUBWOOFERS

Your Image Dynamics subwoofer has been meticulously engineered and designed to handle high power musical reproduction. Despite their rugged construction, it is possible to damage your speaker if they are improperly used. In general, you will hear distortion as a so-called warning before any damage occurs. If you hear distortion in your system, immediately reduce the musical level to the point where the sound retains its clarity.

1. All Image Dynamics subwoofers require an initial break-in period before it will reach optimum performance. Like any new precision machinery, allow a minimum of several days to one week with normal daily usage to ensure that the suspension has properly been broken-in.
2. Be sure you supply the speakers with enough unclipped amplifier power to drive them properly. (More damage can be done to a speaker by under-powering and clipping your amplifier than any other way!)
3. Where possible, run your Speakers in mono instead of stereo. Most bass is reproduced in mono so there is less chance of any cancellation if played in mono.
4. Where possible, wire your Speakers in parallel instead of series. Bass is reproduced either way but again there is less chance of cancellation in parallel. **NOTE: Be sure the amplifier you are using is stable to the resulting impedance of the speaker load!**
5. Where possible, a separate amplifier just for your subwoofers should be used with an electronic crossover to set the frequency range. One amplifier with passive crossovers will work (Tri-Way Setup), but the system will do more with less stress on the amplifier by using two amps.
6. Do not block the front of your speakers. You want as much direct air coupling as possible.

## **BOX CONSTRUCTION**

The material used for enclosure walls should be solid, dense and free of voids or warps. Your enclosure should be made  $\frac{3}{4}$ " or 19mm material, Finland or Baltic birch type plywood is recommended where the enclosure will be transported frequently.

High-density fiberboard - MDF (not chip board) can be used on permanently installed systems. Minimum of 1" (25mm) or double  $\frac{3}{4}$ " (1-1/2") baffle is recommended on high-powered SPL applications.

Corners must be strong and air tight and should not have any air leaks or openings. Joints should be properly filled with glue that will not crack under high stress or impact. If the integrity of the glue seal can't be determined, hot glue or RTV caulking should be used to seal all seams.

Fiber reinforced resin may also be used to form any difficult shapes. However avoid making large panels with resin to eliminate any chances of box flexing, cracking or ratting under high pressure.

Bracing made of 2 x 2" or 2 x 4" should be liberally applied either inside or outside the cabinet, depending on whether the cabinet is to be permanently installed or portable. This principle applies to any walls of the enclosure spanning more than 18" long. Any braces should also be liberally glued or screwed down on edge. Edge-wise drilled, and countersunk holes through the braces can be used for #10-2 Flathead wood screws to avoid the use of more expensive lag bolts.

The majority of strength from an enclosure comes from the glue. When using screws be sure to pre-drill holes to avoid splitting the wood.

**WARNING!** The use of silicone rubber to seal in a speaker will void the Warranty! If any sealing is needed in addition to the speaker's gasket, use caulking cord or vinyl weather strip.

## **SUBWOOFER CROSSOVER SETTING**

Your Image Dynamics subwoofers will perform best if they are used in conjunction with a subwoofer crossover of some kind. Using a crossover will remove unwanted high frequencies and allow them to concentrate only on bass.

The two most common types of crossovers are "passive" or "active" (electronic crossovers are active). Many amplifiers have a built in Low Pass (LPF) electronic crossover circuit. For optimum subwoofer performance we recommend an initial electronic crossover setting between 50-100Hz and then tuning the bass to your liking.

# PARAMETERS FOR IDQ SERIES SUBWOOFERS

(Due to Constant Improvements, Specifications and Parameters are subject to change without notice.)

	<b>IDQ8D2</b>	<b>IDQ8D4</b>	<b>IDQ10D2</b>	<b>IDQ10D4</b>
<b>VC Impedance (ohms)</b>	2Ω + 2Ω	4Ω + 4Ω	2Ω + 2Ω	4Ω + 4Ω
<b>Test Impedance (ohms)</b>	0.94Ω	1.35Ω	0.94Ω	1.35Ω
<b>Driver Displacement</b>	0.05 cu.ft	0.05 cu.ft	0.10 cu.ft	0.10 cu.ft
<b>Fs (Hz)</b>	51	51	42	42
<b>SD (sqCM)</b>	213.82	213.82	380.13	380.13
<b>Vas (Ltr)</b>	6.662	6.191	24.3	21.32
<b>Cms (µm/N)</b>	103	96	119	104
<b>Mms (g)</b>	94.76	90.52	120.4	137.5
<b>BL™</b>	5.525	6.538	5.316	6.579
<b>Qms</b>	6.697	6.172	4.179	4.02
<b>Qes</b>	0.921	0.968	0.992	1.103
<b>Qts</b>	0.807	0.839	0.797	0.868
<b>No (%)</b>	0.0976%	0.0976%	0.176%	0.138%
<b>Spl (dB)</b>	82	84	85	85
<b>Xmax (mm)</b>	14.5mm	14.5mm	14.5mm	14.5mm
<b>Voice Coil Size (inches)</b>	2"	2"	2"	2"
<b>Voice Coil Height mm (inch)</b>	38.3 (1.5")	38.3 (1.5")	38.3 (1.5")	38.3 (1.5")
<b>Voice Coil Type / Former</b>	BASV	BASV	BASV	BASV
<b>Voice Coil Wire</b>	Aluminum	Aluminum	Aluminum	Aluminum
<b>DC Resistance (Ohms)</b>	1.80	3.15	1.80	3.15
<b>Voice Coil Induct @ 1 kHz (MH)</b>	0.79	0.6	0.79	0.6
<b>Frequency Response (Hz)</b>	50-500Hz	50-500Hz	40-500Hz	40-500Hz
<b>Resonant Freq. Fs Hz</b>	51	51	42	42
<b>Motor Structure (ounces)</b>	180 oz	180 oz	180 oz	180 oz
<b>Mounting Depth mm (inch)</b>	125 (4.92")	125 (4.92")	147.5 (5.8")	147.5 (5.8")
<b>Mounting Cutout Diameter mm (inch)</b>	185.4 (7.25")	185.4 (7.25")	243 (9.625")	243 (9.625")
<b>Net Weight (lbs)</b>	12.5 lbs	12.5 lbs	13.55 lbs	13.55 lbs
<b>Power (Rec. RMS/Max RMS)</b>	125/250 watts	125/250 watts	250/500 watts	250/500 watts

\* Please note specifications are tested with coils in parallel configuration



# PARAMETERS FOR IDQ SERIES SUBWOOFERS

(Due to Constant Improvements, Specifications and Parameters are subject to change without notice.)

	<b>IDQ12D2</b>	<b>IDQ12D4</b>
<b>VC Impedance (ohms)</b>	2Ω + 2Ω	4Ω + 4Ω
<b>Test Impedance (ohms)</b>	0.94Ω	1.35Ω
<b>Driver Displacement</b>	0.10 cuft.	0.10 cuft.
<b>Fs (Hz)</b>	34	35
<b>SD (sqCM)</b>	510.72	510.72
<b>Vas (Ltr)</b>	48.5667	47.223
<b>Cms (µm/N)</b>	122	128
<b>Mms (g)</b>	170.6	163.135
<b>BL™</b>	6.54	7.479
<b>Qms</b>	5.381	5.005
<b>Qes</b>	0.786	0.868
<b>Qts</b>	0.681	0.74
<b>No (%)</b>	0.224%	0.223%
<b>Spl (dB)</b>	86	86
<b>Xmax (mm)</b>	14.5 mm	14.5 mm
<b>Voice Coil Size (inches)</b>	2	2
<b>Voice Coil Height mm (inch)</b>	38.3 (1.5")	38.3 (1.5")
<b>Voice Coil Type / Former</b>	BASV	BASV
<b>Voice Coil Wire</b>	Aluminum	Aluminum
<b>DC Resistance (Ohms)</b>	1.4	3.10
<b>Voice Coil Induct @ 1 kHz (MH)</b>	0.79	0.6
<b>Frequency Response (Hz)</b>	35-500Hz	35-500Hz
<b>Resonant Freq. Fs Hz</b>	35	35
<b>Motor Structure (ounces)</b>	280 oz	280 oz
<b>Mounting Depth mm (inch)</b>	146.5 (5.76")	146.5 (5.76")
<b>Mounting Cutout Diameter mm (inch)</b>	276 (10.937")	276 (10.937")
<b>Net Weight (lbs)</b>	20.3 lbs	20.3 lbs
<b>Power (Rec. RMS/Max RMS)</b>	375/750 watts	375/750 watts

\* Please note specifications are tested with coils in parallel configuration

## RECOMMENDED ENCLOSURES

Please note that these enclosure volume recommendations are for the internal airspace inside the enclosure and include the displacement of the subwoofer and ports. When choosing your enclosure type, please pay close attention to your specific woofer, failing to use the correct enclosure may result in lower power handling and poor sound quality. **To calculate the internal airspace required, take the internal dimensions of the box. First multiply these number by themselves and then divide this sum by 1728. (W x H x D) / 1728.**

Please contact your authorized Image Dynamics dealer for other designs and specifications. **(Even though these subwoofers can be used in a ported enclosure, Image Dynamics recommends a sealed enclosure for optimum performance and sound quality)**

### IDQ8 Sealed Enclosures

SEALED ENCLOSURE TYPE	Compact	Universal	Audiophile
Gross Vb Internal	0.33 cu.ft	0.53 cu.ft	0.73 cu.ft
F3 (-3dB Cutoff)	57 Hz	58 Hz	59 Hz
Qtc	0.71	0.62	0.57
Pe (Watts-RMS)	250 Watts	200 Watts	150 Watts

### IDQ10 Sealed Enclosures

SEALED ENCLOSURE TYPE	Compact	Universal	Audiophile
Gross Vb Internal	0.6 cu.ft	1.1 cu.ft	1.6 cu.ft
F3 (-3dB Cutoff)	45 Hz	40 Hz	38 Hz
Qtc	1.18	0.96	0.87
Pe (Watts-RMS)	450 Watts	350 Watts	250 Watts

### IDQ12 Sealed Enclosures

SEALED ENCLOSURE TYPE	Compact	Universal	Audiophile
Gross Vb Internal	0.65 cu.ft	1.0 cu.ft	1.8 cu.ft
F3 (-3dB Cutoff)	50 Hz	45 Hz	42 Hz
Qtc	1.14	0.97	0.8
Pe (Watts-RMS)	650 Watts	550 Watts	375 Watts

## IDQ8 Ported Enclosures

PORTED ENCLOSURE TYPE	Compact	Universal	Audiophile
Gross Vb Internal	0.5 cu.ft	0.75 cu.ft	1.0 cu.ft
Port Frequency	40 Hz	40 Hz	40 Hz
F3 (-3dB Cutoff)	37 Hz	34 Hz	32 Hz
Port Dimensions	2" x 9"	2" x 5.5"	2" x 3.75"
Port Displacement	0.02 cu.ft	0.011 cu.ft	0.007 cu.ft
Slot Port Opening	6" x 1.0"	6" x 1.0"	6" x 1.0"
Slot Port Length	17.25"	10.65"	7.40"
Slot Port Displacement	0.60 cu.ft	0.04 cu.ft	0.03 cu.ft

## IDQ10 Ported Enclosures

PORTED ENCLOSURE TYPE	Compact	Universal	Audiophile
Gross Vb Internal	1.0 cu.ft	1.45 cu.ft	1.75 cu.ft
Port Frequency	40 Hz	35 Hz	30 Hz
F3 (-3dB Cutoff)	37 Hz	31 Hz	28 Hz
Port Dimensions	4" x 18.24"	4" x 16.14"	4" x 18.58"
Port Displacement	0.13 cu.ft	0.12 cu.ft	0.14 cu.ft
Slot Port Opening	10" x 1.5"	10" x 1.5"	10" x 1.5"
Slot Port Length	22.07"	19.56"	22.47"
Slot Port Displacement	0.19 cu.ft	0.17 cu.ft	0.20 cu.ft

## IDQ12 Ported Enclosures

PORTED ENCLOSURE TYPE	Compact	Universal	Audiophile
Gross Vb Internal	1.0 cu.ft	1.5 cu.ft	2.0 cu.ft
Port Frequency	40 Hz	35 Hz	30 Hz
F3 (-3dB Cutoff)	42 Hz	36 Hz	32 Hz
Port Dimensions	4" x 18.25"	4" x 15.5"	4" x 15.9"
Port Displacement	0.13 cu.ft	0.11 cu.ft	0.12 cu.ft
Slot Port Opening	26.82 sq in.	22.90 sq in.	23.45 sq in.
Slot Port Length	26.82"	22.90"	23.45"
Slot Port Displacement	0.28 cu.ft	0.24 cu.ft	0.24 cu.ft

# IDQ v4 DIMENSIONS AND MEASUREMENTS

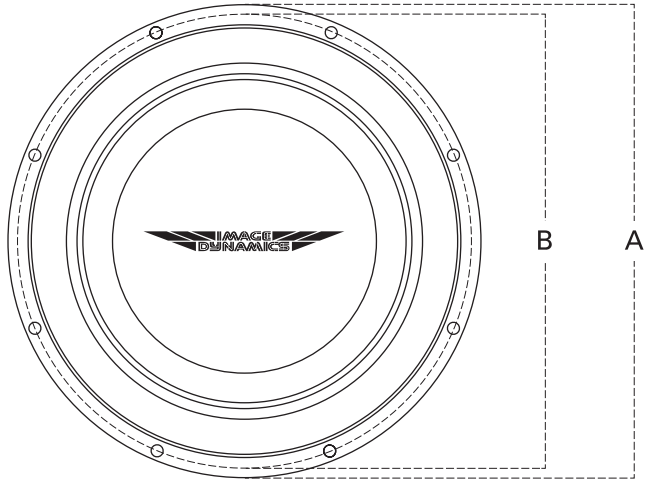

	A	B
<b>IDQ8v4</b>	8.35"	7.25"
<b>IDQ10v4</b>	11.04"	9.625"
<b>IDQ12v4</b>	12.46"	10.937"

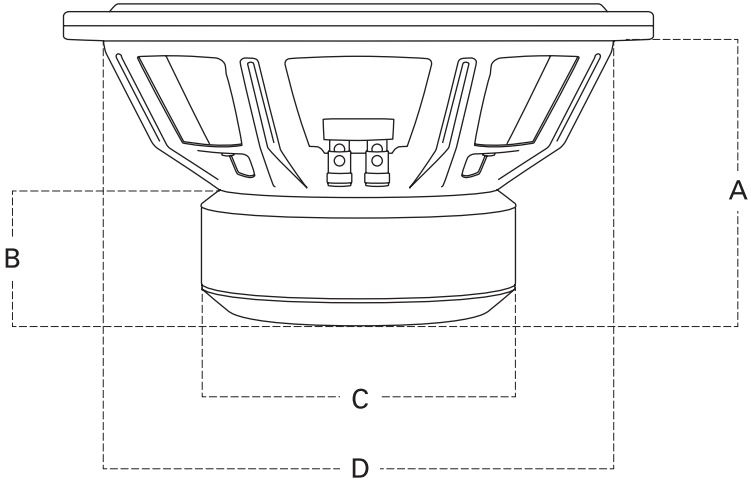

	A	B	C	D
<b>IDQ8v4</b>	4.95"	2.52"	5.52"	7.26"
<b>IDQ10v4</b>	5.81"	2.52"	5.52"	9.57"
<b>IDQ12v4</b>	5.91"	2.52"	5.52"	10.87"

# IMAGE DYNAMICS LIMITED WARRANTY POLICY

Image Dynamics USA, Inc. offers limited warranty on Image Dynamics products under normal use on the following terms:

**Image Dynamics Speakers are to be free of defects in material and workmanship for a period of one (1) year.**

This warranty applies only to Image Dynamics products sold to consumers by Authorized Image Dynamics Dealers in the United States of America. Products purchased by consumers from a Image Dynamics dealer in another country are covered only by that country's Distributor and not by Image Dynamics USA.

This warranty covers only the original purchaser of Image Dynamics product. In order to receive service, the purchaser must provide Image Dynamics with the receipt stating the consumer name, dealer, product and date of purchase.

Products found to be defective during the warranty period will be repaired or replaced (with a product deemed to be equivalent) at Image Dynamics's discretion and will not be liable for incidental or consequential damages. Image Dynamics will not warranty this product under the following situations:

- **Speakers received with bent frames or water damage**
- **Abuse such as holes in the cone, surround or ripped spider**
- **Voice coil damage due to amplifier clipping or distortion**
- **Product that has not been installed according to this owners manual**

Any implied warranties including warranties of fitness for use and merchantability are limited in duration to the period of the express warranty set forth above. Some states do not allow limitations on the length of an implied warranty, so this limitation may not apply. No person is authorized to assume for Image Dynamics any other liability in connection with the sale of this product.

**Please call (909) 930-1377 for Image Dynamics Customer Service.** You must obtain an RA# (Return Authorization Number) to return any product to Image Dynamics. The RA number must be prominently marked on the outside of the shipping carton or the delivery will be refused. Please pack your return carefully; we are not responsible for items damaged in shipping. Return the defective product along with a copy of the original dated retail sales receipt.

**Image Dynamics USA, Inc.,  
Attn: Returns (RA# \_\_\_\_\_)  
2133 S. Green Privado Ontario, CA 91761**

Residents of HI, AK and US territories will be charged for return shipping. All inquires regarding service and warranty should be sent to the above address.

**Removed or altered serial numbers will void this warranty**

This manual is the exclusive property of Image Dynamics USA, Inc. Any reproduction of this manual, or use other than its intentions is strictly prohibited without the express consent of Image Dynamics USA, Inc. Copyright 2023 Image Dynamics USA, Inc.





Image Dynamics USA  
2133 S. Green Privado – Ontario, CA 91761  
Tel. (909) 930-1377 – Fax (866) 239-4399

**[www.imagedynamicsusa.net](http://www.imagedynamicsusa.net)**